

Click sound

SLOKY®

Cat.06

***Torque Tool
and Screwdriver***



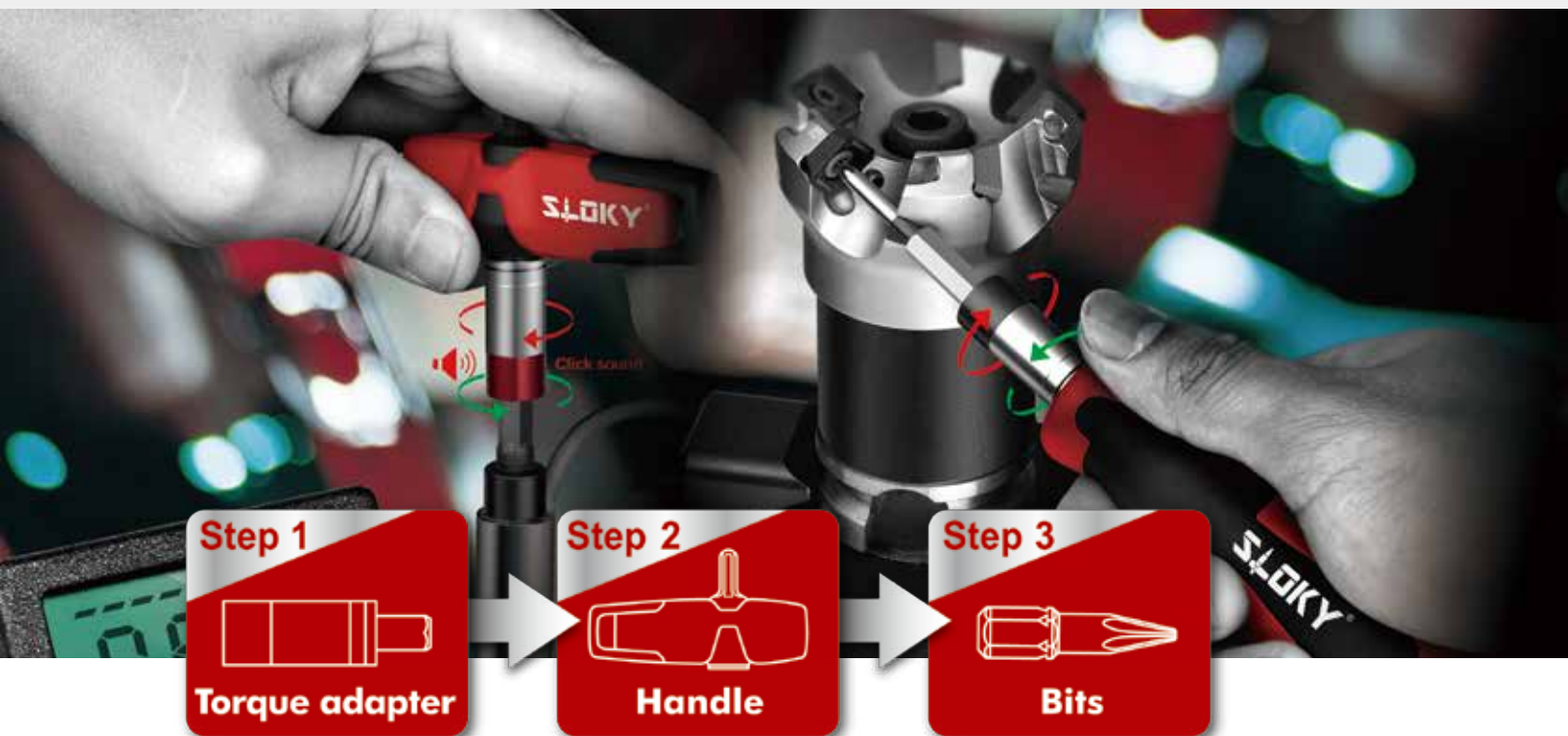

A bout Us 

Torque Adapter

Standard Torque Adapter (0.6 ~ 5.5Nm)

0-TPK-A



01

Extend Torque Adapter (6 ~ 18Nm)

0-TPK-ETA
0-TPK-ETB
0-TPK-ETC



14

Mini Torque Adapter (0.1 ~ 0.7Nm)

0-TPK-MTA



15

Handle

Universal Handle
Slim-Fit Handle
T Flying Handle

0-TPK-H01
0-TPK-H02
0-TPK-H03



03

Bits

0-TPK-B01
0-TPK-B01...HP
0-TPK-B02
0-TPK-B03

TORX®	25mm 50mm 75mm
High Precision TORX®	25mm 50mm
TORX PLUS®	25mm 50mm 75mm
HEXAGON	25mm 50mm



05

Contents

Pro Station

0-TPK26-PR

TORX®
TORX PLUS®
HEXAGON

50mm bits
50mm bits
50mm bits



09

Togo Kit

0-TPK01
0-TPK02
0-TPK03

TORX®
TORX PLUS®
HEXAGON

25mm+50mm bits
25mm+50mm bits
25mm+50mm bits



10

Work Station

0-TPK01
0-TPK02
0-TPK03

TORX®
TORX PLUS®
HEXAGON

25mm+50mm bits
25mm+50mm bits
25mm+50mm bits



11

Smart Kit

0-TPK01

TORX®

25mm bits



12

Single Set

0-TPK01
0-TPK02
0-TPK03

TORX®
TORX PLUS®
HEXAGON

25mm+50mm bits
25mm+50mm bits
25mm+50mm bits



Accessory

- Torque Analyzer
- Magnet Tool Stand



16

User Guide



17

About Us

“SLOKY®” comes from the meaning of “SOLO KEY” in Taiwanese dialogue.

It is defined from the position of patented adapter in torque screwdriver system as a solo performer.

Patented adapter plays as a solo performer, with a unique feature to build whole product system. The torque's value is setting on the adapter; complied with various bits and handles become torque screwdrivers for tighten or loosen the screw.

Sloky torque screwdriver, a predicable, replaceable and organized tool.

It is considering to be used in industrial field having a greatest advantage of “no-over tighten”.

It prevents the damages of the screw and tool, in addition it provides a replaceable function to fit with driver bits having different shape and dimensions.

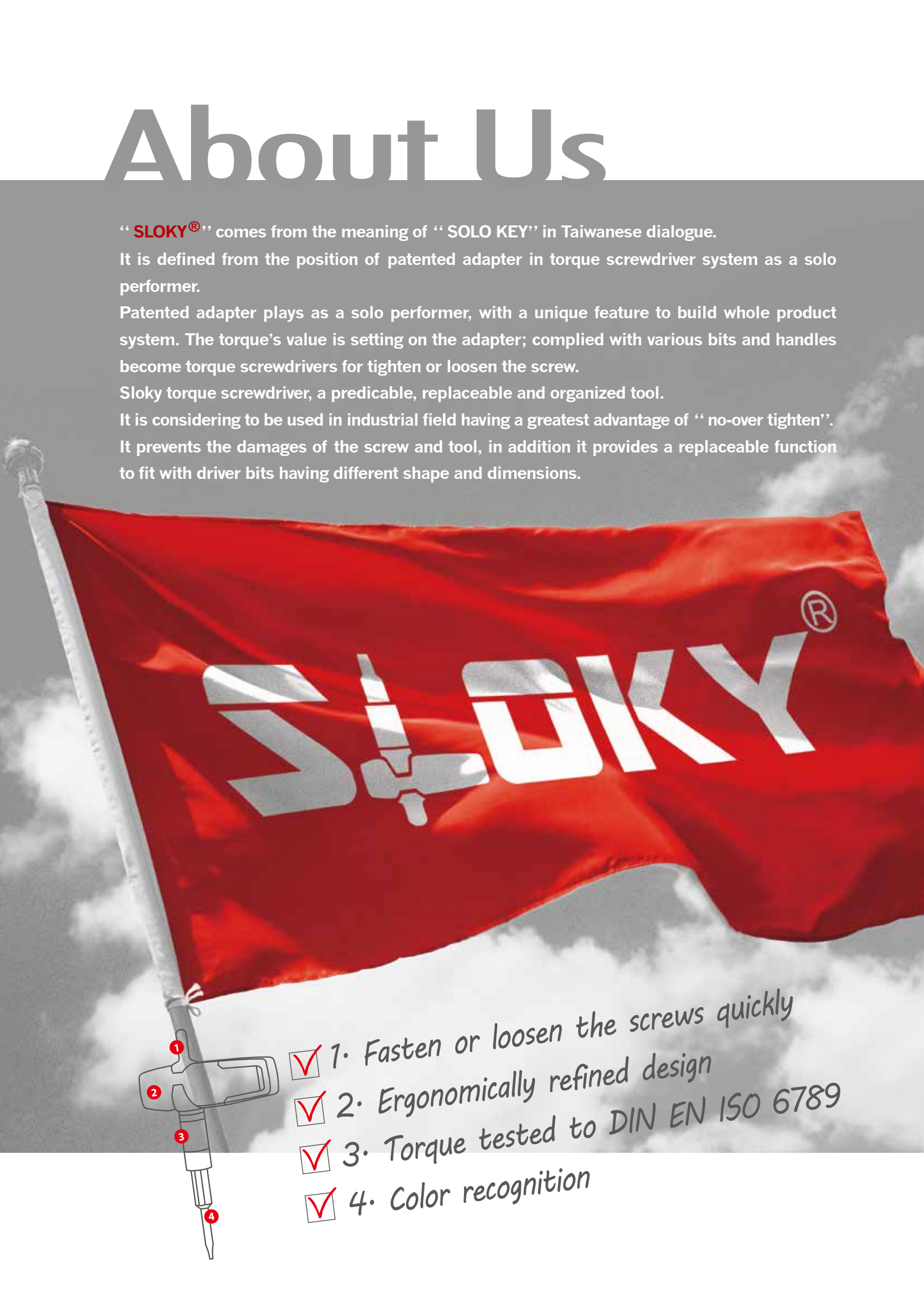
- 
- The image features a large red flag with the SLOKY logo in white, set against a background of a cloudy sky. In the bottom left corner, there is a diagram of a torque screwdriver with four numbered callouts (1, 2, 3, 4) pointing to specific parts of the tool. To the right of the diagram is a list of four features, each preceded by a checkmark in a box.
- ✓ 1. Fasten or loosen the screws quickly
 - ✓ 2. Ergonomically refined design
 - ✓ 3. Torque tested to DIN EN ISO 6789
 - ✓ 4. Color recognition

Predictable



- When the demand torque is reached, there is a click sound. For continued tightening on the screw, it is no longer to increase the torque on the screw.
- It has a reversible system to use the same screwdriver for tightening and loosening the screw.
- The limit of loosening torque is larger than the tightening torque to protect both tool and the screw from the breaking or damage.

*High efficiency
High quality
Highlight of Product*

Replaceable



- Not only the bit, the torque adapter is also replaceable.
- Light and precise! Ideal as economic torque screwdriver.
- Fitting with a universal handle, the most compact size of torque screwdriver in the world is built.
- The cost of the torque adapter is lower in comparison with other brands.
- Different torque value preset adapter is available on request.



Organized



- Persisting highest quality to supply SLOKY products and services to meet customer's satisfactions.
- Accomplishing customer's requirements by professional technology.

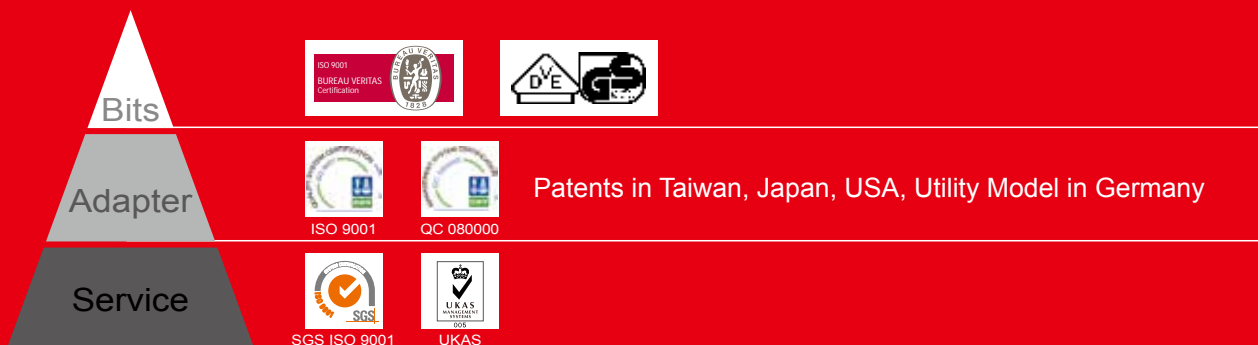

Adapter

Principle

"No- over tighten" adapter is created from the non-return ratchet torque socket. It comprised a shaft rod and a shaft cylinder.

A core shaft of shaft rod is sleeved with a mobile ratchet capable of axially moving; the shaft cylinder has a shaft slot formed for being sleeved with the core shaft.

When the core shaft rotates in the shaft slot and the applied torque exceeds the preset torque value, the core shaft idly rotates in the shaft slot.

It means when the demand torque is reached, continued tightening is no longer to increase the torque on the screw.

- Different connecting and / or driving parts are available on request.
- Torque range is possible from 0.1Nm~18Nm.



✓ 20,000 times product life test



Used Screwdriver
Without Torque

Used Screwdriver
With Torque

- Material : Carbon Steel
- Hardness : HRC 43° ~ 48°
- Surface Treatment : Electroless Nickel
- Unit conversion : 1 Nm = 10.20kgf-cm
- Torque tested to DIN EN ISO 6789
- 30% Higher torque for loosening

30% Higher Torque
For Loosening



Adapter

Installed with magnet for C6.3 and E6.3 bits

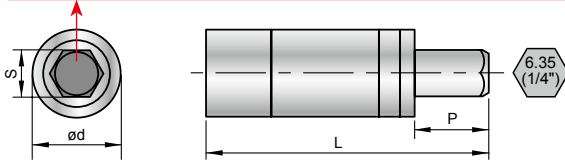

Your own exclusive kit

Choosing any 12 adapters
to create your own Torque Kit.

Parts No.: 0-TPK12-EX (MOQ:3 kits)



Torque Accuracy : ±10%

Parts No.	Nm	KgfcM	In-lb	Q'TY	Ød (mm)	S (mm)	P (mm)	L (mm)	N.W.	Packaging Illustration
0-TPK-A06-0.6	0.6	6.1	5.3	3 pcs	12	6.35 (1/4")	10	38.3	80g	
0-TPK-A07-0.9	0.9	9.2	8.0							
0-TPK-A08-1.2	1.2	12.0	10.6							
0-TPK-A08-2.0	2.0	20.4	17.7							
0-TPK-A09-1.4	1.4	14.0	12.4							
0-TPK-A09-2.0	2.0	20.4	17.7							
0-TPK-A10-2.0	2.0	20.4	17.7							
0-TPK-A15-3.0	3.0	30.6	26.6							
0-TPK-A20-5.0	5.0	51.0	44.3							
0-TPK-A20-5.5	5.5	56.1	48.7							
0-TPK-A25-5.5	5.5	56.1	48.7							

Parts No.	Nm	KgfcM	In-lb	Q'TY	Ød (mm)	S (mm)	P (mm)	L (mm)	N.W.	Packaging Illustration
0-TPK-A00-2.5	2.5	25.5	22.1	3 pcs	12	6.35 (1/4")	10	38.3	80g	
0-TPK-A00-3.8	3.8	38.7	33.6							
0-TPK-A00-4.0	4.0	40.8	35.4							
0-TPK-A00-4.5	4.5	45.9	39.8							

• Special torque adapter or torque accuracy ±6% are available on request.

⚠ This product is only suitable for manual operation. Do not apply with other electric tools or power tools.

Handle

Use same torque screwdriver to fasten and loosen your screw.

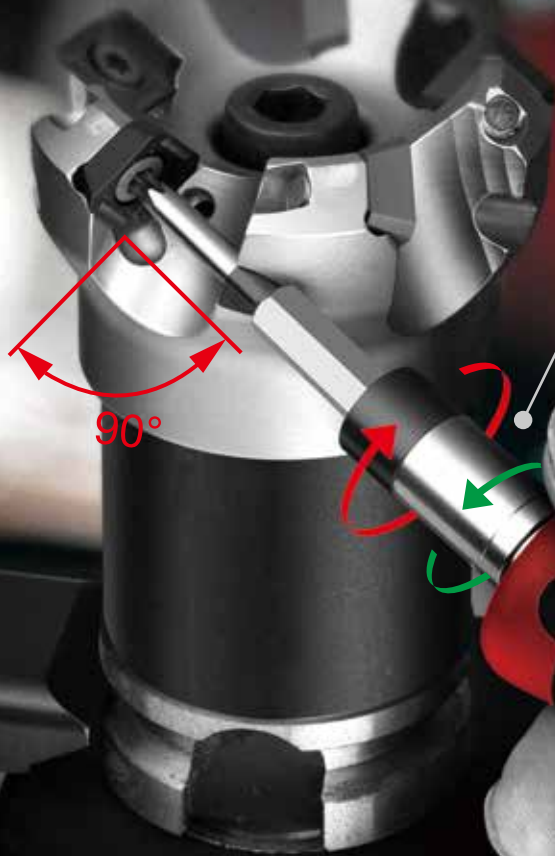

Features

We offer **3** different types of handle to cover all torque adapters.

The soft zone is comfortable to hold and play very flexible. Easy to tighten and loosen screws even in higher torque range.

The outstanding design of the SLOKY handle that fits perfectly into the hand and prevents the hand injuries such as blisters and calluses.

✓ The ergonomic design of the handle



Universal Handle

Features :

- Universal type for holding in multi-ways.
- Having large support surfaces for thumb and index finger ease of using and efficiency.
- Remaining the advantages of flag design, driving the screw easily.

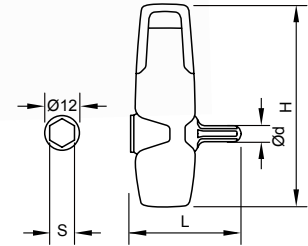

Fig	Parts No.	Suit For Torque	Color	S (mm)	L (mm)	H (mm)	Ød (mm)	N.W.
1	0-TPK-H01	0.6~5.5 Nm	Red	6.35 (1/4")	37.5	70.7	5	25g
	0-TPK-H01-B		Blue					

Slim-Fit Handle

Features :

- Slim fit for comfortable holding, for accurate and efficient while fastening and loosening small sizes screws

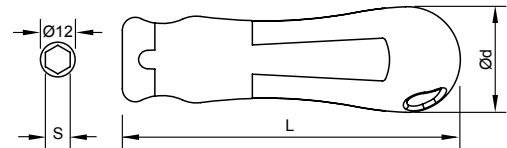

Fig	Parts No.	Suit For Torque	Color	S (mm)	L (mm)	Ød (mm)	N.W.
2	0-TPK-H02	0.6~2.0 Nm	Red	6.35 (1/4")	104	32.5	50g
	0-TPK-H02-B		Blue				

T Flying Handle

Features :

- It is light, even it is designed for higher torque.
- The striking soft zone that allows particularly comfortable, best handle for using at higher torque.

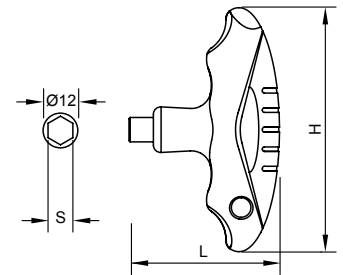
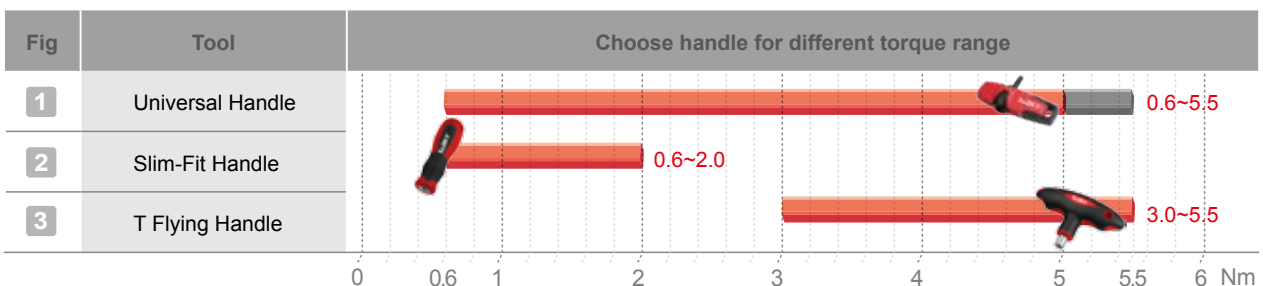

Fig	Parts No.	Suit For Torque	Color	S (mm)	L (mm)	H (mm)	N.W.
3	0-TPK-H03	3.0~5.5 Nm	Red	6.35 (1/4")	65	100	60g
	0-TPK-H03-B		Blue				

Choose handle for different torque range



Bits

Color Identity

No mistake!

The color identification is visible on both adapters and bits.

Select suitable torque size by color management system indicated on torque adapters and bits.

It is to enhance the convenience of using and delivery proper tightening torque.



TORX®



TORX PLUS®



HEXAGON

TX20 / 20IP / H4
TX25 / 25IP / H5

TX15 / 15IP / H3

TX10 / 10IP / H2.5

TX9 / 9IP

TX8 / 8IP / H2

TX7 / 7IP

TX6 / 6IP / H1.5



High Precision Torx Bits



✓ Tools created from ideas

Spare

Hardness : HRC 58° ~60°
Material : High alloy steel

- TORX® drive between tool and screw by line or surface contact rather than point contact.
- It also increases the amount of torque and force that can be transferred.



- **25mm Bits for TORX® screws**
- **HP High Precision Bits for TORX® screws**
(Ordering code example: 0-TPK-B01-TX06-25HP)
Standard : DIN3126 – C6.3 (1/4")

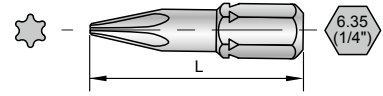

Parts No.	Driver Size	L (mm)	Q'TY	N.W.	Packaging Illustration
0-TPK-B01-TX06-25	TX6	25	6 pcs	32 g	
0-TPK-B01-TX07-25	TX7			32 g	
0-TPK-B01-TX08-25	TX8			32 g	
0-TPK-B01-TX09-25	TX9			32 g	
0-TPK-B01-TX10-25	TX10			32 g	
0-TPK-B01-TX15-25	TX15			34 g	
0-TPK-B01-TX20-25	TX20			34 g	



- **50mm Bits for TORX® screws**
- **HP High Precision Bits for TORX® screws**
(Ordering code example: 0-TPK-B01-TX06-50HP)
Standard : Similar to DIN3126 – C6.3 (1/4")

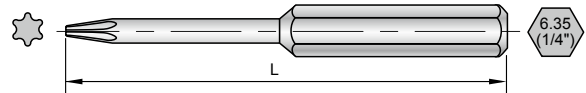

Parts No.	Driver Size	L (mm)	Q'TY	N.W.	Packaging Illustration
0-TPK-B01-TX06-50	TX6	50	6 pcs	54 g	
0-TPK-B01-TX07-50	TX7			54 g	
0-TPK-B01-TX08-50	TX8			54 g	
0-TPK-B01-TX09-50	TX9			56 g	
0-TPK-B01-TX10-50	TX10			58 g	
0-TPK-B01-TX15-50	TX15			60 g	
0-TPK-B01-TX20-50	TX20			62 g	
0-TPK-B01-TX25-50	TX25	62 g			

- **75mm Bits for TORX® screws**
Standard : Similar to DIN3126 – E6.3 (1/4")

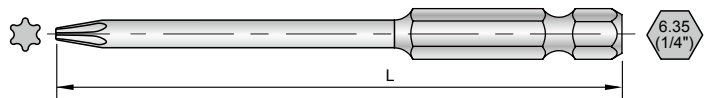

Parts No.	Driver Size	L (mm)	Q'TY	N.W.	Packaging Illustration
0-TPK-B01-TX08-75	TX8	75	6 pcs	58 g	
0-TPK-B01-TX09-75	TX9			64 g	
0-TPK-B01-TX10-75	TX10			70 g	
0-TPK-B01-TX15-75	TX15			70 g	
0-TPK-B01-TX20-75	TX20			78 g	
0-TPK-B01-TX25-75	TX25			88 g	

TORX® and TORX PLUS® are registered trademarks of Acument Global Technologies.



- Larger contact surface between tool and screw.
- The line of effective force is in the direction of movement (direction of rotation).

Spare

Hardness : HRC 58° ~60°
Material : High alloy steel

25mm Bits for TORX PLUS® screws
Standard : DIN3126 – C6.3 (1/4")

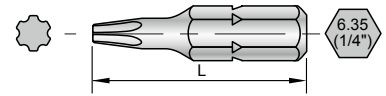

Parts No.	Driver Size	L (mm)	Q'TY	N.W.	Packaging Illustration
0-TPK-B02- 6IP-25	6IP	25	6 pcs	32 g	
0-TPK-B02- 7IP-25	7IP			32 g	
0-TPK-B02- 8IP-25	8IP			32 g	
0-TPK-B02- 9IP-25	9IP			32 g	
0-TPK-B02-10IP-25	10IP			32 g	
0-TPK-B02-15IP-25	15IP			34 g	
0-TPK-B02-20IP-25	20IP			34 g	

50mm Bits for TORX PLUS® screws
Standard : Similar to DIN3126 – C6.3 (1/4")

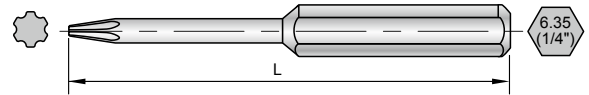

Parts No.	Driver Size	L (mm)	Q'TY	N.W.	Packaging Illustration
0-TPK-B02- 6IP-50	6IP	50	6 pcs	54 g	
0-TPK-B02- 7IP-50	7IP			54 g	
0-TPK-B02- 8IP-50	8IP			54 g	
0-TPK-B02- 9IP-50	9IP			56 g	
0-TPK-B02-10IP-50	10IP			58 g	
0-TPK-B02-15IP-50	15IP			60 g	
0-TPK-B02-20IP-50	20IP			62 g	
0-TPK-B02-25IP-50	25IP	66 g			

75mm Bits for TORX PLUS® screws
Standard : Similar to DIN3126 – E6.3 (1/4")

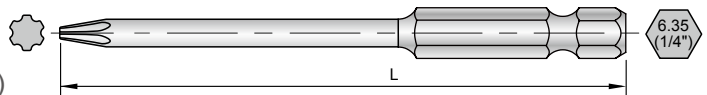

Parts No.	Driver Size	L (mm)	Q'TY	N.W.	Packaging Illustration
0-TPK-B02- 8IP-75	8IP	75	6 pcs	64 g	
0-TPK-B02- 9IP-75	9IP			66 g	
0-TPK-B02-10IP-75	10IP			72 g	
0-TPK-B02-15IP-75	15IP			72 g	
0-TPK-B02-20IP-75	20IP			78 g	
0-TPK-B02-25IP-75	25IP			86 g	

TORX® and TORX PLUS® are registered trademarks of Acument Global Technologies.

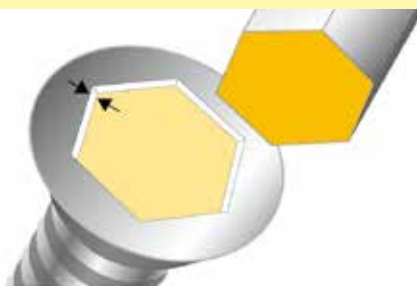

• Screwdriver bit with external hexagon profile.

Spare

Hardness : HRC 58° ~60°
Material : High alloy steel

25mm Bits for HEXAGON screws

Standard : DIN3126 – C6.3 (1/4")

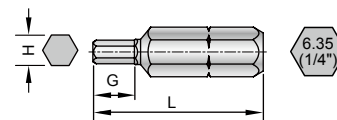

Parts No.	Driver Size	H (mm)	G (mm)	L (mm)	Q'TY	N.W.	Packaging Illustration
0-TPK-B03-H015-25	H1.5	1.5	2.3	25	6 pcs	32 g	
0-TPK-B03-H020-25	H2	2.0	3.0			32 g	
0-TPK-B03-H025-25	H2.5	2.5	3.8			33 g	
0-TPK-B03-H030-25	H3	3.0	4.5			34 g	
0-TPK-B03-H040-25	H4	4.0	6.0			36 g	
0-TPK-B03-H050-25	H5	5.0	7.5			40 g	

50mm Bits for HEXAGON screws

Standard : DIN3126 – E6.3 (1/4")

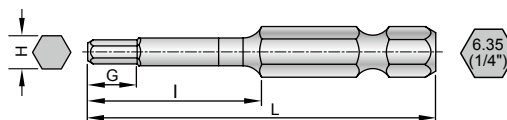

Parts No.	Driver Size	H (mm)	G (mm)	I (mm)	L (mm)	Q'TY	N.W.	Packaging Illustration
0-TPK-B03-H015-50	H1.5	1.5	2.3	25	50	6 pcs	50 g	
0-TPK-B03-H020-50	H2	2.0	3.0				51 g	
0-TPK-B03-H025-50	H2.5	2.5	3.8				54 g	
0-TPK-B03-H030-50	H3	3.0	4.5				57 g	
0-TPK-B03-H040-50	H4	4.0	6.0				64 g	
0-TPK-B03-H050-50	H5	5.0	7.5				72 g	



Pro Station



Parts No.: 0-TPK26-PR-22K

All-in-One **TORX®** **TORX PLUS®** **HEXAGON** tools for professional using

Handle	Contents										N.W.
	Adapter				50mm Bits for TORX®		50mm Bits for TORX PLUS®		50mm Bits for HEXAGON		
	Nm	KgfcM	In-lb	Q'TY	Size	Q'TY	Size	Q'TY	Size	Q'TY	
 TPK-H02-B	0.6	6.1	5.3	1PC	TX6	1PC	6IP	1PC	H1.5	1PC	1600g
	0.9	9.2	8.0		TX7		7IP		-	-	
	1.2	12.0	10.6		TX8		8IP		H2	1PC	
 TPK-H01-B	1.4	14.0	12.4		TX9		9IP		-	-	
	2.0	20.4	17.7		TX10		10IP		H2.5	1PC	
	3.0	30.6	26.6		TX15		15IP		H3		
 TPK-H03-B	5.0	51.0	44.3		TX20		20IP		H4		
	5.5	56.1	48.7		TX25		25IP		H5		

Tool Stand

Parts No.: 0-TPK26-PR

N.W.: 1000g

- For all Sloky torque tools.
- Tool stand is made of aluminum alloy, silver coating.







TX



IP



H

6~18Nm
Dia.20

0.2~5.5Nm
Dia.12

0.1~0.7Nm
Dia.8

Click sound

- Let <CLICK> tell you when the torque is reached!
- Quick release!

Rapid-out

- Simply pull the bit outward to change new bit.
- Perfect positioning in the bits.

Color recognition

- The color identification is visible on both adapters and bits.

Torque Adapter

- Special torque adapter is available on request from 0.1~18 Nm by different adapter size.

KEEP YOUR SCREW SAFE

INNOVATION

Patented in multi-country:

TW / M439546

CN / ZL201220320077.3

US / 8833211

DE / 102012005885.3

JP / 3181981



Togo Kit

Collecting the most popular torque tools
Ready to go.

Torque Screwdriver Kit for **TORX®** , 25mm+50mm Bits

Parts No.	Contents						N.W.	Packaging Illustration
	Handle	Adapter			Bit			
		Size	Nm	KgfcM	In-lb	25mm+50mm		
0-TPK01-TGTX-12K	TPK-H02	TX6	0.6	6.1	5.3	1 pc + 1 pc	445g	
		TX7	0.9	9.2	8.0			
		TX8	1.2	12.0	10.6			
	TPK-H01	TX9	1.4	14.0	12.4			
		TX10	2.0	20.4	17.7			
		TX15	3.0	30.6	26.6			

Torque Screwdriver Kit for **TORX PLUS®** , 25mm+50mm Bits

Parts No.	Contents						N.W.	Packaging Illustration
	Handle	Adapter			Bit			
		Size	Nm	KgfcM	In-lb	25mm+50mm		
0-TPK02-TGIP-12K	TPK-H02-B	6IP	0.6	6.1	5.3	1 pc + 1 pc	445g	
		7IP	0.9	9.2	8.0			
		8IP	1.2	12.0	10.6			
	TPK-H01-B	9IP	1.4	14.0	12.4			
		10IP	2.0	20.4	17.7			
		15IP	3.0	30.6	26.6			

Torque Screwdriver Kit for **HEXAGON** , 25mm+50mm Bits

Parts No.	Contents						N.W.	Packaging Illustration
	Handle	Adapter			Bit			
		Size	Nm	KgfcM	In-lb	25mm + 50mm		
0-TPK03-TGHX-12K	TPK-H02	H1.5	0.6	6.1	5.3	1 pc + 1 pc	445g	
		H2.0	1.2	12.0	10.6			
		H2.5	2.0	20.4	17.7			
	TPK-H01	H3.0	3.0	30.6	26.6			
		H4.0	5.0	51.0	44.3			
		H5.0	5.5	56.1	48.7			

TORX® and TORX PLUS® are registered trademarks of Acument Global Technologies.

⚠ This product is only suitable for manual operation. Do not apply with other electric tools or power tools.

Work Station *For your long time using and storage.*

Torque Screwdriver Kit for **TORX®** , 25mm+50mm Bits

Parts No.	Contents						N.W.	Packaging Illustration
	Handle	Adapter				Bit 25mm+50mm		
		Size	Nm	KgfcM	In-lb			
0-TPK01-PR-12	TPK-H02	TX6	0.6	6.1	5.3	1 pc + 1 pc	855g	
		TX7	0.9	9.2	8.0			
		TX8	1.2	12.0	10.6			
	TPK-H01	TX9	1.4	14.0	12.4			
		TX10	2.0	20.4	17.7			
		TX15	3.0	30.6	26.6			

Torque Screwdriver Kit for **TORX PLUS®** , 25mm+50mm Bits

Parts No.	Contents						N.W.	Packaging Illustration
	Handle	Adapter				Bit 25mm+50mm		
		Size	Nm	KgfcM	In-lb			
0-TPK02-PR-12	TPK-H02-B	6IP	0.6	6.1	5.3	1 pc + 1 pc	855g	
		7IP	0.9	9.2	8.0			
		8IP	1.2	12.0	10.6			
	TPK-H01-B	9IP	1.4	14.0	12.4			
		10IP	2.0	20.4	17.7			
		15IP	3.0	30.6	26.6			

Torque Screwdriver Kit for **HEXAGON** , 25mm+50mm Bits

Parts No.	Contents						N.W.	Packaging Illustration
	Handle	Adapter				Bit 25mm + 50mm		
		Size	Nm	KgfcM	In-lb			
0-TPK03-PR-12	TPK-H02	H1.5	0.6	6.10	5.30	1 pc + 1 pc	855g	
		H2.0	1.2	12.0	10.6			
		H2.5	2.0	20.4	17.7			
	TPK-H01	H3.0	3.0	30.6	26.6			
		H4.0	5.0	51.0	44.3			
		H5.0	5.5	56.1	48.7			

TORX® and TORX PLUS® are registered trademarks of Acument Global Technologies.

⚠ This product is only suitable for manual operation. Do not apply with other electric tools or power tools.

Smart Kit

Cover the smallest 0.6Nm to biggest 5.5Nm adapters with one universal handle.

Torque Screwdriver Kit for TORX® , 25mm Bits



Parts No.	Contents						N.W.	Metric Screw	Packaging Illustration
	Handle	Adapter				Bit			
		Size	Nm	KgfcM	In-lb	25mm			
0-TPK01-99-06K	TPK-H01	TX6	0.6	6.1	5.3	1pc	290g	M1.8 M2	
		TX7	0.9	9.2	8.0			M2 M2.2	
		TX8	1.2	12.0	10.6			M2.2 M2.5	
		TX9	2.0	20.4	17.7			M3 M3.5	
		TX15	3.0	30.6	26.6			M3.5 M4	
		TX20	5.5	56.1	48.7			M5 M5.5	

Smart Kit
Single Set

Single Set

Economical Starter

Torque Screwdriver Single Set for TORX® , 25mm+50mm Bits

Parts No.	Contents						N.W.	Packaging Illustration
	Handle	Adapter			Bit			
		Nm	KgfcM	In-lb	Size	25mm+50mm		
0-TPK01-TX06-0.6-S	TPK-H02	0.6	6.1	5.3	TX6	2 pcs + 2 pcs	122g	
0-TPK01-TX07-0.9-S		0.9	9.2	8.0	TX7			
0-TPK01-TX08-1.2-S		1.2	12.0	10.6	TX8			
0-TPK01-TX08-2.0	TPK-H01	2.0	20.4	17.7	TX8	2 pcs + 2 pcs	130g	
0-TPK01-TX09-1.4		1.4	14.0	12.4	TX9			
0-TPK01-TX09-2.0		2.0	20.4	17.7				
0-TPK01-TX10-2.0		2.0	20.4	17.7	TX10			
0-TPK01-TX15-3.0		3.0	30.6	26.6	TX15			
0-TPK01-TX20-5.0		5.0	51.0	44.3	TX20			
0-TPK01-TX20-5.5	5.5	56.1	48.7	TX20	200g			
0-TPK01-TX2025-5.5	TPK-H03	5.5	56.1	48.7			TX20	2 pcs
							TX25	2 pcs

TORX® and TORX PLUS® are registered trademarks of Acument Global Technologies.

⚠ This product is only suitable for manual operation. Do not apply with other electric tools or power tools.

Single Set *Economical Starter*

Torque Screwdriver Single Set for **TORX PLUS®** , 25mm+50mm Bits

Parts No.	Contents						N.W.	Packaging Illustration
	Handle	Adapter			Bit			
		Nm	KgfcM	In-lb	Size	25mm+50mm		
0-TPK02- 6IP-0.6-S	TPK-H02-B	0.6	6.1	5.3	6IP		130g	
0-TPK02- 7IP-0.9-S		0.9	9.2	8.0	7IP	2 pcs + 2 pcs		
0-TPK02- 8IP-1.2-S		1.2	12.0	10.6	8IP			
0-TPK02- 9IP-1.4	TPK-H01-B	1.4	14.0	12.4	9IP		130g	
0-TPK02-10IP-2.0		2.0	20.4	17.7	10IP	2 pcs + 2 pcs		
0-TPK02-15IP-3.0		3.0	30.6	26.6	15IP			
0-TPK02-20IP-5.0		5.0	51.0	44.3	20IP			
0-TPK02-2025IP-5.5	TPK-H03-B	5.5	56.1	48.7		Bit 50mm	200g	
					20IP	2 pcs		
					25IP	2 pcs		

Torque Screwdriver Single Set for **HEXAGON** , 25mm+50mm Bits

Parts No.	Contents						N.W.	Packaging Illustration
	Handle	Adapter			Bit			
		Nm	KgfcM	In-lb	Size	25mm+50mm		
0-TPK03-H020-1.2	TPK-H02	1.2	12.0	10.6	H2	2 pcs + 2 pcs	150g	
0-TPK03-H025-2.0	TPK-H01	2.0	20.4	17.7	H2.5	2 pcs + 2 pcs	135g	
0-TPK03-H030-3.0		3.0	30.6	26.6	H3			
0-TPK03-H040-5.0	TPK-H03	5.0	51.0	44.3	H4	Bit 50mm	200g	
						4 pcs		

TORX® and TORX PLUS® are registered trademarks of Acument Global Technologies.

⚠ This product is only suitable for manual operation. Do not apply with other electric tools or power tools.

Extend Torque Adapter

6 ~ 18 Nm



Extend Torque Adapter

EX : Connecting Part	Torque Adapter	EX : Driving Part
1/4" Hex Drive Ratchet T-handle Handle	0-TPK-ETA 1/4" Hex 1/4" Hex 	 Torx bits Torx Plus bits Hex bits Flat head bits PH bits long bits
1/4" Square Drive Sliding T-handle Ratchet Handle	0-TPK-ETB 1/4" Square 1/4" Hex 	 Square Socket Socket Bit_P2 Socket Bit_Hex
3/8" Square Drive T-handle Handle Ratchet	0-TPK-ETC 3/8" Square 3/8" Square 	 Square Socket Socket Bit_P2 Socket Bit_Hex

Specification :

Parts No.	Nm	KgfcM	Inlb	ød(mm)	S(mm)	P(mm)	L(mm)	H(mm)	
0-TPK-ETA-6.0	6.0	61.1	53.1						
0-TPK-ETA-8.0	8.0	81.5	70.8		6.32	10	43.5	6.38	
0-TPK-ETA-10.0	10.0	101.9	88.5						
0-TPK-ETB-8.0	8.0	81.5	70.8	20					
0-TPK-ETB-10.0	10.0	101.9	88.5		6.43	--	44.5	6.38	
0-TPK-ETB-12.0	12.0	122.3	106.2						
0-TPK-ETC-8.0	8.0	81.5	70.8						
0-TPK-ETC-10.0	10.0	101.9	88.5	9.65	12	53.0	9.47		
0-TPK-ETC-12.0	12.0	122.3	106.2						

Custom Design :

1. Identify which type of torque adapter you need

0-TPK-ETA
 0-TPK-ETB
 0-TPK-ETC

2. Determine the torque range from 6Nm to 18Nm

0-TPK-ETA- _____ Nm 0-TPK-ETB- _____ Nm 0-TPK-ETC- _____ Nm

“Click” Sound



Reversible system



Torque accuracy : ±10%



* Delivery time : around 8~12 weeks

* MOQ : 30 pcs

Mini Torque Adapter

Mini Torque Adapter

"No over tighten"

Specification :

Torque Accuracy : ±10%

Parts No.	Nm	KgfcM	Inlb
0-TPK-MTA-0.1	0.1	1.0	0.9
0-TPK-MTA-0.2	0.2	2.0	1.8
0-TPK-MTA-0.3	0.3	3.1	2.7
0-TPK-MTA-0.4	0.4	4.1	3.5
0-TPK-MTA-0.5	0.5	5.1	4.4
0-TPK-MTA-0.6	0.6	6.1	5.3
0-TPK-MTA-0.7	0.7	7.1	6.2
0-TPK-H05	Mini Handle		

Installed with magnet

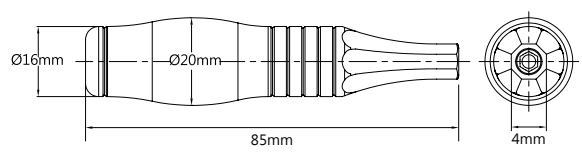
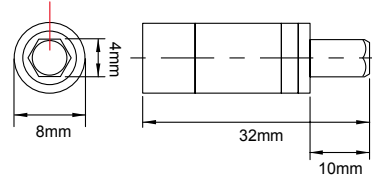

Parts No.: 0-TPK-H05

A total solution for applications below :

- Communication Devices
- Consumer Electronics
- Drones/UAV
- Smart Phones
- Printed Circuit Boards
- Watches

Transform normal screwdriver to torque screwdriver

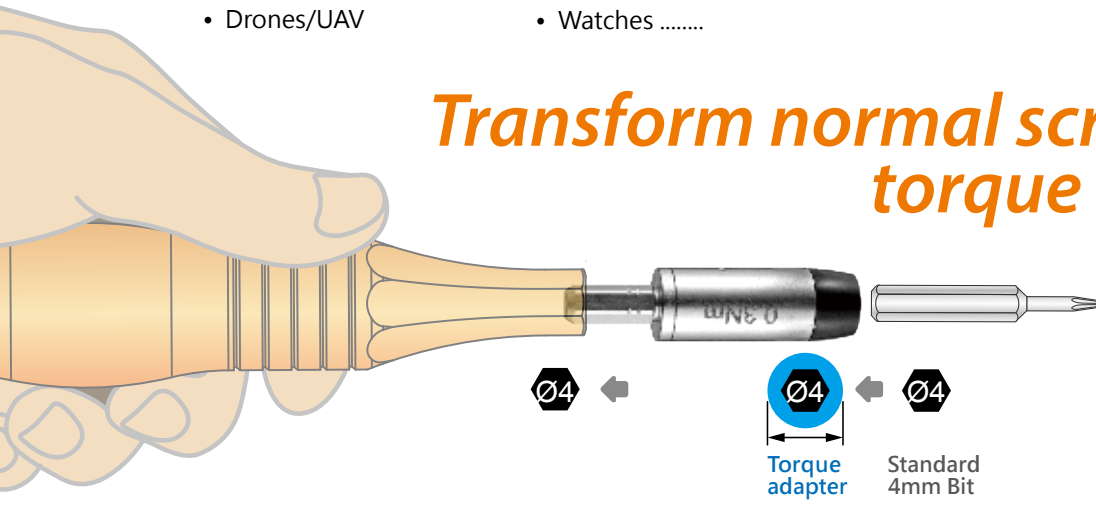

SLOKY mini torque adapter fits almost any kinds of the 4mm bits and handle with Ø4 mm in the market.

Torque control and safety for "High-Value" products

Mini **0.1 ~ 0.7Nm**



Accessory

Torque Analyzer (Made in Japan)

Parts No.: 08-CD-100M



Model No.		CD-100M
Measuring Range	Nm	0.10~10.00
	kgf-cm	1.0~100.0
	lbf-in	1.0~90.0
Accuracy		±0.5% (199 or less digit ± 1 digit)
Display		The 3.5 figures digital display of LCD
Measurement Mode	P-P	The maximum under measurement is always displayed.
	T-R	The value of the load torque concerning a detector is displayed as it is.
	P-D	A value when a load torque value changes from a rise to descent is displayed.
Transmission interface		USB (Baud rate : 19200)
Auto Power Off		Power-supply OFF is carried out after the neglect during 10 minutes.
Battery		Ni-cd battery : 1.2V/5sells (700mAh)
Charge time / Use time		About 3 hours / About 12 hours use consecutive at full charge time
Size / Weight		160(W) X 125(D) X 55(H)mm / 1kg
Measurement Joint	Spec.	SJ-50
	Measurement Range	0.5~5 Nm

3 Seats Magnet Tool Stand

- ✓ Quick and fix on anywhere with metal surface.
- ✓ Acrylic material with magnet support up to 1 kg.
- ✓ All SLOKY screwdrivers can be fit with.

Parts No.: 9999-TPK-03S



✓ Your Best Workshop Tool

▲Not include torque screwdriver

User Guide

Why the torque may get low after use a certain time?

The torque adapter is functional by the radial direction friction; it is different from the marketed product nowadays. When an object slips or is going to slip with another object, on the two contact faces will create a relative action. This relative action is called the static friction, it creates the abrasion after use a certain time. The preset torque of adapter may get low due to this abrasion.

How to judge?

- $\pm 10\%$ allowance for torque adapter is acceptable.
- Please check it on Torque analyzer or measurement.

The tips of using different handle

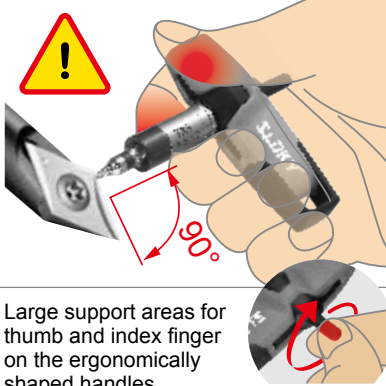

Large support areas for thumb and index finger on the ergonomically shaped handles.

The transmission of high torques is thus quite simple. Cylindrical handle shaft for quick turning of screws.



The Slim Fit handle has been designed to fit snugly in your hand, making blisters and calluses a thing of the past, even after intensive use. The handle hard zones allows the hand to easily glide during hand repositioning. The soft zones ensures full force transfer through the grip.



The T Flying handle is needed whenever particularly high torque for loosening or tightening jobs needs to be applied.

The power is transferred positively, there is no frictional loss between the hand and the handle.

Simple operation



All adapters with magnetic, the bits can be inserted and automatically locked into the adapters.

Exchange bits system with colour coding

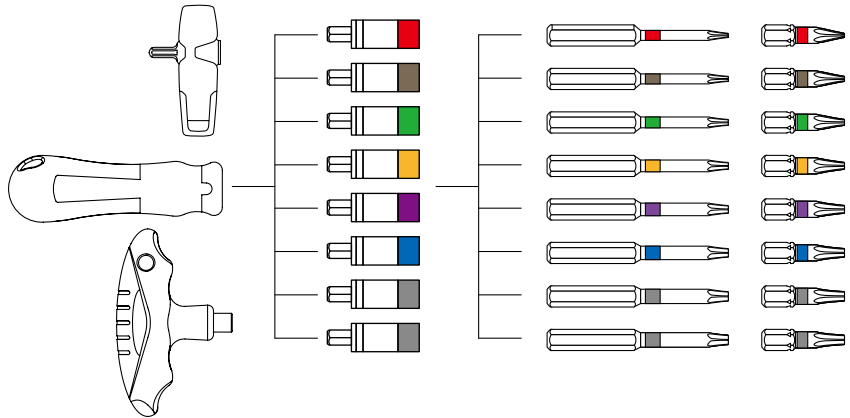

Precise Laboratory Systems



Smallest torque adapter for

SLOKY®
Torque Tool & Screwdriver

Custom Design to meet your specific applications

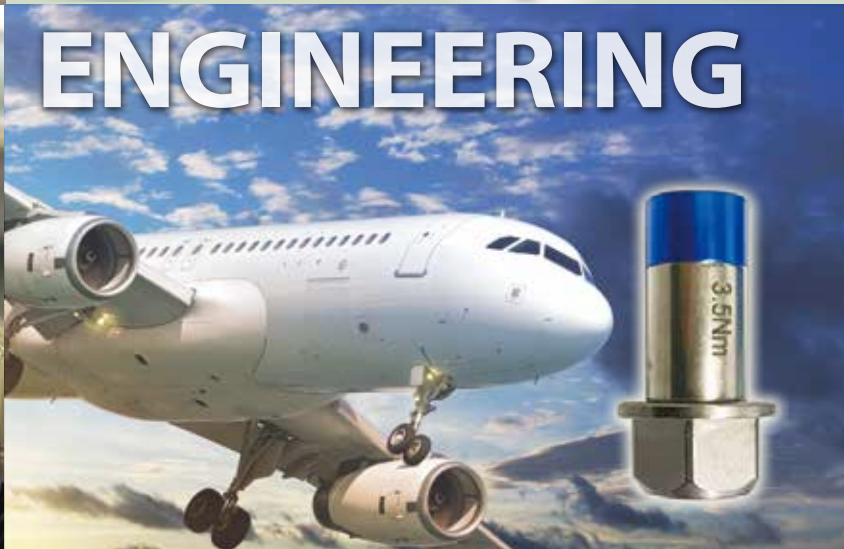

Features:

- No over-tighten
- "Click" Sound
- Torque Accuracy $\pm 6\% \sim \pm 10\%$
- Color Identify
- Patented

Specification:

- Torque range: 0.1 ~ 18 Nm
- Connecting and Driving portion can be designed by your order.

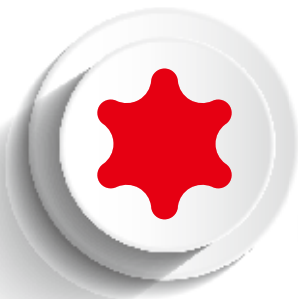

JIMMORE
International Corp.

